

<b>CONTENTS (ENGLISH)</b>		<b>Page No</b>
1	INTRODUCTION	2
2	UNPACKING	2
3	F8, F10 AND S12 OVERVIEW	2
3.1	F8 Full-range system	3
3.2	F10 Full-range system	3
3.3	S12 Sub-bass system	4
3.4	Grille removal	4
4	SAFETY FIRST	5
5	AMPLIFICATION	6
6	CONNECTIONS	7
7	CABLE LENGTHS	7
8	SYSTEM CONFIGURATIONS	7
8.1	Passive systems	8
8.2	Bi-amped systems	9
9	WARRANTY	10
10	TECHNICAL SPECIFICATIONS	11



**The Martin Experience**

All material © 2007. Martin Audio Ltd. Subject to change without notice.

**Martin Audio – Blackline F8, F10, S12**



Standards Applied

EMC Emission	EN55103-1:1996
Immunity	EN55103-2:1996
Electrical Safety	EN60065:1993

This equipment conforms to the requirements of the EMC Directive 89/336/EEC, amended by 92/31/EEC and 93/68/EEC and the requirements of the Low Voltage Directive 73/23/EEC, amended by 93/68/EEC.

## 1 INTRODUCTION

---

Thank you for purchasing a Martin Audio Blackline Series system. The Blackline Series is a range of portable loudspeaker enclosures designed for a variety of portable sound reinforcement and club applications.

Blackline products covered in this user's guide include the F8 and F10 full-range systems and S12 sub-bass enclosure.

For optimum performance, it is recommended that Blackline Series systems be used with an M3 or DX1 electronic controller. The controller provides crossover, EQ and limiter functions for bi-amped Blackline configurations and may also be used as an optional equaliser and limiter for the full-range F8 and F10. Please refer to the M3 or DX1 user's guide for further information.

## 2 UNPACKING

---

Each Martin Audio Blackline Series loudspeaker is built to the highest standard and thoroughly inspected before it leaves the factory. After unpacking the system, examine it carefully for any signs of transit damage and inform your dealer if any such damage is found. It is suggested that you retain the original packaging so that the system can be repacked at a future date if necessary. Please note that Martin Audio and its distributors cannot accept any responsibility for damage to any returned product through the use of non-approved packaging.

## 3 F8, F10, S12 OVERVIEW

---

The Blackline F8, F10 and S12 are ideally suited to applications that require very compact size, high output and ease of transportation. They also make ideal fill-in speakers for use with larger Blackline systems and their very small size is particularly useful in situations that require visually discrete monitors.

### 3.1 F8 Full-range system

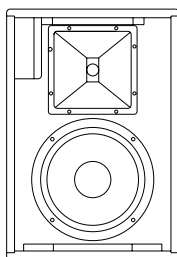

(Fig 1)

The F8 is a versatile, 2-way passive system designed for applications where high output is required from an ultra-compact enclosure. It features a long excursion 8" (200mm) low frequency driver and a 1" (25mm) HF compression driver mounted on a constant directivity 90° x 50° horn.

With its multi-angle cabinet and rotatable horn, it can be tripod mounted or used as an ultra-compact floor monitor. To rotate the horn for horizontal use, remove the grille (see 3.4 below), unscrew the horn and rotate it through 90 degrees.

The enclosure is provided with ten M8 threaded inserts and four M6 bracket inserts for a variety of mounting configurations. It is also provided with a top hat fitting for use with a tripod or as a pole socket for mounting above a Blackline subwoofer.

Use of a controller with the F8 is optional. For demanding applications, use with an M3 or DX1 electronic controller is recommended.

### 3.2 F10 Full-range system

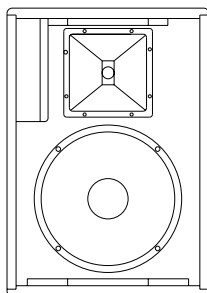

(Fig 2)

The F10 is a 2-way passive system, designed to provide exceptional club sound reinforcement and stage monitoring from a very compact enclosure. It features a powerful 10" (250mm) low frequency driver and a 1" (25mm) HF compression driver mounted on a constant directivity 90° x 50° horn.

Depending on the application, the HF horn can be rotated to allow the

multi-angle enclosure to be used in either its vertical or horizontal orientation. To rotate the horn for horizontal use, remove the grille (see 3.4 below), unscrew the horn and rotate it through 90 degrees.

The enclosure is provided with ten M8 threaded inserts and four M8 bracket inserts for a variety of mounting configurations. It is also provided with a top hat fitting for use with a tripod or as a pole socket for mounting above a Blackline subwoofer.

Use of a controller with the F10 is optional. For demanding applications, use with an M3 or DX1 electronic is recommended.

### 3.3 S12 Sub-bass system

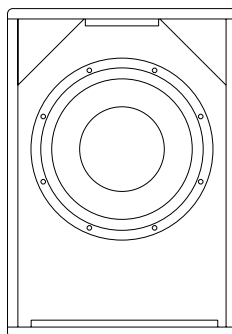

(Fig 3)

The S12 is an extremely compact sub-bass system. It has been designed for use with the F8 and F10 full-range loudspeakers systems in situations where extended low frequency output and increased system headroom are required. When used with an F8 or F10, it will extend the response of the complete system to below 45Hz.

It features a high power 12" (300mm)/3" (75mm) voice coil, long excursion drive unit reflex loaded in a birch plywood enclosure. It can operate in either passive add-on mode using its own internal switchable passive network or may be used actively with an M3 or DX1 controller. In the active configuration, the controller will provide crossover, EQ and limiter functions for the S12 and F8/F10 combination. Please refer to the M3 or DX1 user's guide for further information.

The S12 is provided with a top hat fitting that can be used as a pole socket to mount an F8 or F10 above the enclosure.

### 3.4 Grille Removal

To remove the grille, first remove any grille retaining screws. The grille can then be removed by inserting a flat bladed screwdriver under one of the notches at the top and bottom of the grille then gently levering the grille out of the side channels.

## 4 SAFETY FIRST

---

It is important that loudspeaker systems are used in a safe manner. Please take some time to review the following points concerning safe use of Blackline Series loudspeakers.

Professional loudspeakers are capable of producing extremely high sound levels and should be used with care. Hearing loss is cumulative and can result from levels above 90dB if people are exposed for a long period. Never stand close to loudspeakers driven at a high level.

### **Tripod Mounting**

The F8 and F10 incorporate a pole mounting socket to facilitate mounting on tripod stands. When using stands, the following precautions are advised:

Ensure that the stand will support the weight of the speaker by checking the stand manufacturers rating.

Make sure that the stand is placed on a level surface and that its legs are fully extended.

Do not place more than one speaker on each stand.

Run cables so that they do not present a trip hazard which could pull the speaker over.

When used outdoors in the wind, it may be necessary to add some weight to the base of the stand.

When using a pole mount with a sub-bass system, observe similar precautions.

### **Stacking**

Ensure that the floor or stage is level and solid.

Do not stack speakers too high outdoors where winds could topple the stack.

Be aware that speakers producing very high power levels can move or creep. To avoid this, place friction material between the floor and speaker and between each speaker.

### **Rigging and Suspension**

**WARNING:** Suspending the system should only be done by qualified personnel following safe rigging practices. Secure fixings to the building structure are vital. Seek help from architects, structural engineers or other specialists if in any doubt.

Blackline Series enclosures are designed for portable applications, but can be suspended singly by means of the threaded inserts provided or by

compatible Martin Audio wall Brackets. The F8, F10 enclosures are fitted internally with steel corner reinforcement brackets to ensure that each cabinet is strong enough to be hung from its top. **Never suspend one enclosure from another to form an array or cluster using these fittings.**

The common practice of using commercially available eye bolts for suspension should only be undertaken with great caution. Eye bolts are strongest along the thread axis. Angling the enclosure will result in an angle pull and it is important to use eye bolts that are safe in these circumstances. Only forged shoulder eye bolts should be considered and it is important that the thread length is at least 30mm. A flat washer should be inserted between the eyebolt and the enclosure. **Formed eye bolts i.e. those which are formed from a steel rod bent into an eye should be avoided.**

## 5 AMPLIFICATION

---

The F8, F10, and S12 systems are designed to be used with professional power amplifiers capable of producing the following power outputs into 4 ohms:

F8	200 – 600 W
F10	400 – 650 W
S12	400 – 800 W

Care should be taken to avoid amplifier clipping. It is important to understand that a low power amplifier driven into clipping is more likely to damage a loudspeaker than a higher power amplifier used within its ratings. This is because music signals have a high peak-to-average "crest" factor. When an amplifier is severely overdriven, its output waveform is clipped (its peaks are squared off) – reducing the crest factor. In extreme cases, the waveform can approach that of a square wave. An amplifier is normally capable of producing far more power under these conditions than its undistorted rated power output. The use of very high power amplifiers with outputs greater than those recommended is discouraged.

Care should be taken to avoid switch-on surges, which can result in momentary power peaks in excess of specified ratings. When powering up a sound system it is important to switch on the amplifiers after the mixer and control electronics have stabilised. When powering down the system, reverse the sequence and switch off the amplifiers first.

## 6 CONNECTIONS

Each connector panel has two Neutrik Speakon connectors wired in parallel with each other. The second connector allows use of a short link lead to power another parallel loudspeaker. The connectors are wired as follows:

F8/F10/S12 Passive

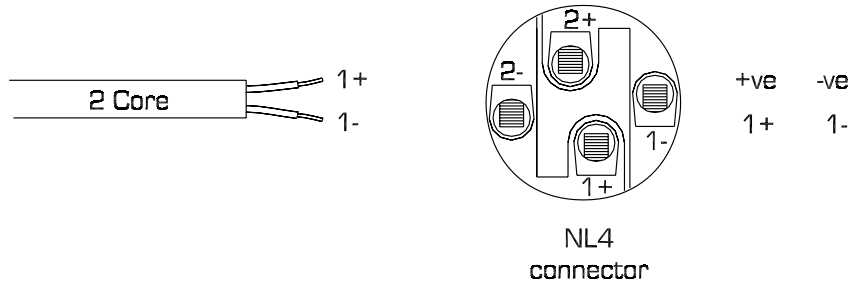

(Fig 4)

## 7 CABLE LENGTHS

When connecting Blackline systems to an amplifier, it is recommended that the return resistance of the cable used is less than one tenth of the nominal impedance of the system or systems in parallel. The table below gives an indication of the maximum permissible cable runs for various conductor cross-sectional areas.

Conductor CSA	Maximum Cable Run		
	4 ohms	8 ohms	16 ohms
1.0mm <sup>2</sup>	11m	22m	44m
1.5mm <sup>2</sup>	17m	34m	68m
2.0mm <sup>2</sup>	22m	44m	88m
2.5mm <sup>2</sup>	29m	58m	116m
4.0mm <sup>2</sup>	44m	88m	176m
6.0mm <sup>2</sup>	66m	132m	264m

## 8 SYSTEM CONFIGURATIONS

There are many different system combinations possible when the F8 and F10 full-range systems are used with the S12 and other Blackline sub-bass systems. Shown below are some typical configurations. The number of F8 or F10 full-range systems required to match the efficiency of one sub-bass system is shown as a recommended cabinet ratio (RCR). Please note that for simplicity each line in the diagram represents a pair of wires.

## 8.1 Passive systems

### F8/F10 Full-range

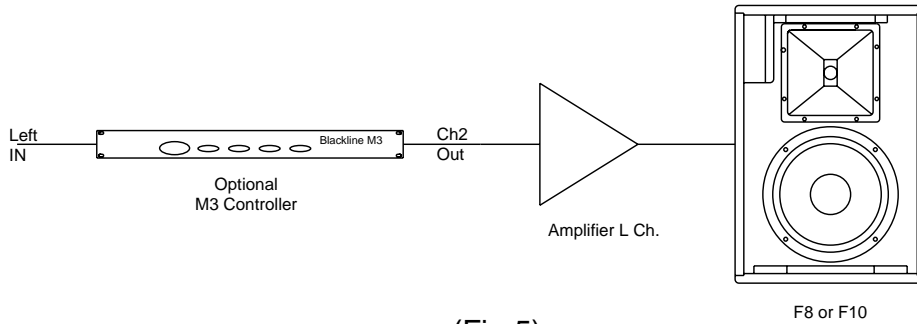

(Fig 5)

Because the F8 and F10 are passive systems embodying correct acoustic design principles, they can be used without a controller provided recommended amplifier power is not exceeded and care is taken to avoid amplifier clipping. Use of an optional M3 or DX1 controller with its system specific low frequency EQ and built-in limiters will result in improved bass response and system protection.

### F8/F10 Full-range with add-on S12/S15

The F8 and F10 can be used with either the S12 or S15 in passive add-on mode. For maximum bass power, it is also possible to combine the F10 passively with an S18 sub-bass.

The passive add-on arrangement provides a simple way of increasing bass performance without the need for an additional amplifier. The switch at the back of the sub-bass enclosure should be switched to "passive" and a link lead run from the sub-bass to the F8 or F10. This configuration will present a 4 ohm load to the amplifier. An M3 or DX1 controller for this passive configuration is optional – just performing limiting functions without any additional system EQ.

F8 with S12/S15 RCR = 2:1

F10 with S18 RCR = 2:1

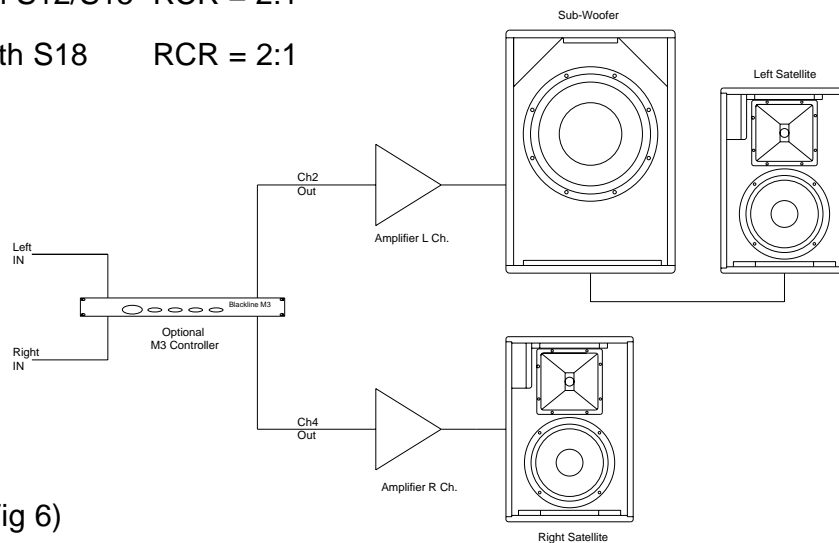

(Fig 6)



F10 with S12/S15 RCR = 1:1

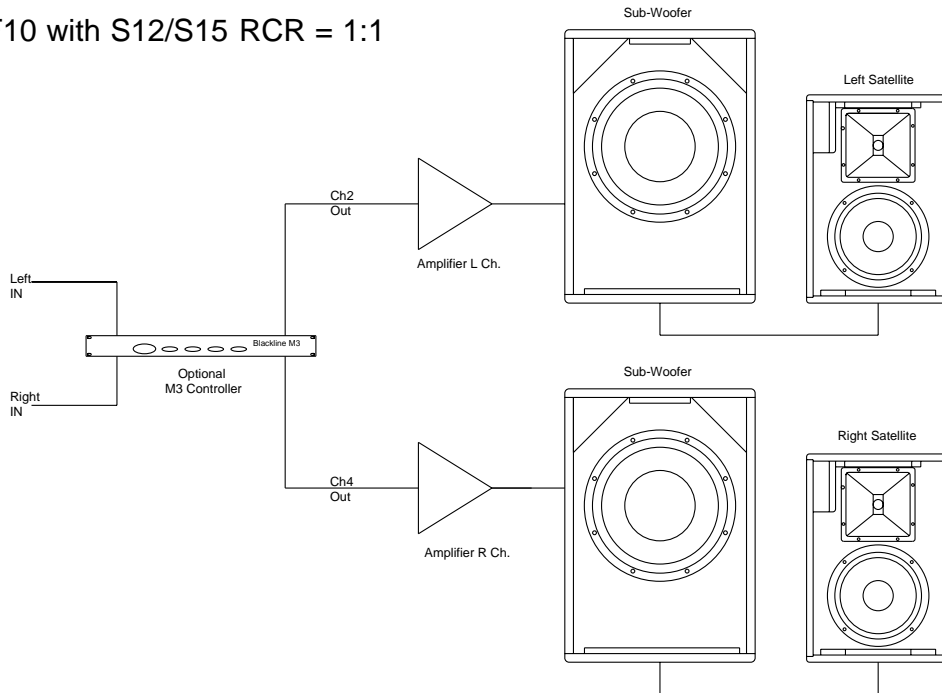

(Fig 7)

## 8.2 Bi-amped systems

The switch at the back of the sub-bass enclosure should be switched to "active".

F8 with S12/S15 RCR = 2:1

F10 with S18 RCR = 2:1

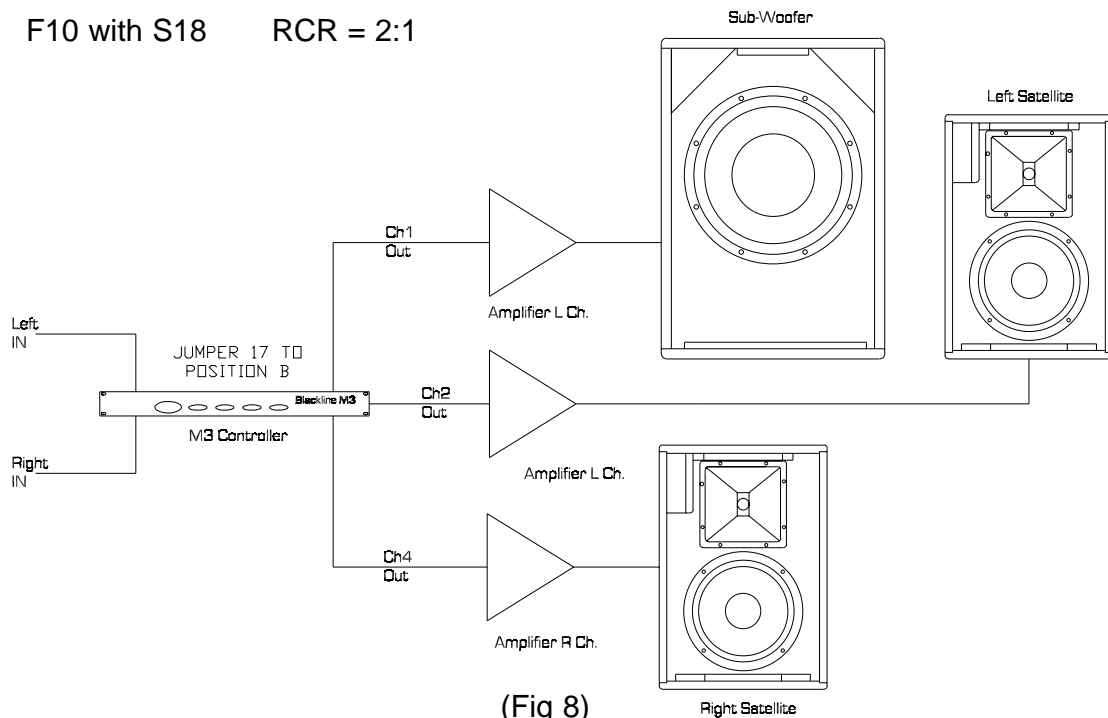

(Fig 8)

F10 with S12/S15 RCR = 1:1

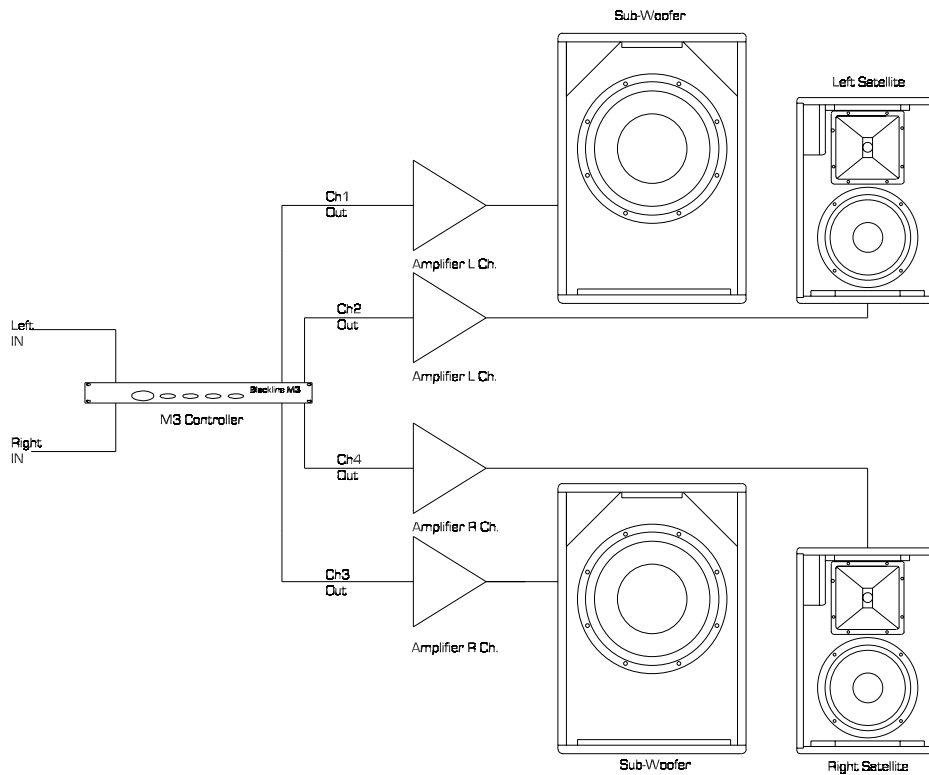

(Fig 9)

## 9 WARRANTY

Martin Audio Blackline Series products are warranted against manufacturing defects in materials or craftsmanship over a period of 5 years from the date of original purchase. During the warranty period Martin Audio will, at its discretion, either repair or replace products which prove to be defective provided that the product is returned in its original packaging, shipping prepaid, to an authorised Martin Audio service agent or distributor.

Martin Audio Ltd. cannot be held responsible for defects caused by unauthorised modifications, improper use, negligence, exposure to inclement weather conditions, act of God or accident, or any use of this product that is not in accordance with the instructions provided by Martin Audio. Martin Audio is not liable for consequential damages.

This warranty is exclusive and no other warranty is expressed or implied. This warranty does not affect your statutory rights.

## 10 TECHNICAL SPECIFICATIONS

---

### **F8**

TYPE	Ultra-compact, two way passive
FREQUENCY RESPONSE (1)	70Hz-20kHz $\pm$ 3dB
LOW FREQUENCY LIMIT	55Hz (-10dB)
DRIVERS	1 x 8" (200mm)/2"(50mm) voice coil LF driver 1 x 1" (25mm) exit HF compression driver
RATED POWER (2)	150W AES, 600W peak
RECOMMENDED AMPLIFIER	200-600W into 4 ohms
SENSITIVITY (3)	93dB
MAXIMUM SPL (4)	113dB continuous, 119dB peak
IMPEDANCE	8 ohms nominal
DISPERSION (-6DB)	90° H x 50° V
CROSSOVER	2.5kHz passive
ENCLOSURE	14.8 litre (0.5 cu foot) vented, multi-laminate birch ply
FINISH	Textured black paint
PROTECTIVE GRILLE	Black perforated steel
CONNECTORS	2 x Neutrik Speakon NL4
FITTINGS	10 x M8 threaded inserts 4 x M6 inserts for HTKM10 wall bracket 1 x top hat fitting
DIMENSIONS	(W) 299mm x (H) 435mm x (D) 269mm (W) 11.8ins x (H) 17.1ins x (D) 10.6ins
WEIGHT	12kg (26lbs)
SHIPPING DIMENSIONS	(W) 330mm x (H) 600mm x (D) 620mm (W) 13ins x (H) 23.7ins x (D) 24.5ins
SHIPPING WEIGHT	27.5kg (60.5lbs) (packed in pairs)

**F10**

TYPE	Compact, two way passive
FREQUENCY RESPONSE (1)	65Hz-20kHz $\pm$ 3dB
LOW FREQUENCY LIMIT	56Hz (-10dB)
DRIVERS	1 x 10" (250mm)/2 1/2"(63mm) voice coil LF driver 1 x 1" (25mm) exit HF compression driver
RATED POWER (2)	300W AES, 1200W peak
RECOMMENDED AMPLIFIER	400-650W into 4 ohms
SENSITIVITY (3)	96dB
MAXIMUM SPL (4)	119dB continuous, 125dB peak
IMPEDANCE	8 ohms nominal
DISPERSION (-6DB)	90° H x 50° V
CROSSOVER	2kHz passive
ENCLOSURE	23 litre (0.8 cu foot) vented, multi-laminate birch ply
FINISH	Textured black paint
PROTECTIVE GRILLE	Black perforated steel
CONNECTORS	2 x Neutrik Speakon NL4
FITTINGS	10 x M8 threaded inserts 4 x M8 inserts for HTKM20 wall bracket 1 x top hat fitting
DIMENSIONS	(W) 351mm x (H) 500mm x (D) 317mm (W) 13.8ins x (H) 19.7ins x (D) 12.5ins
WEIGHT	17kg (37lbs)
SHIPPING DIMENSIONS	(W) 430mm x (H) 470mm x (D) 580mm (W) 17ins x (H) 18.5ins x (D) 23ins
SHIPPING WEIGHT	20kg (44lbs)

**S12**

TYPE	Compact sub-bass system
FREQUENCY RESPONSE (1)	52Hz-150Hz $\pm$ 3dB
LOW FREQUENCY LIMIT	43Hz (-10dB)
DRIVER	1 x 12" (300mm)/3" (75mm) voice coil LF driver
RATED POWER (2)	400W AES, 1600W peak
RECOMMENDED AMPLIFIER	400-800W into 4 ohms
SENSITIVITY (3)	96dB
MAXIMUM SPL (4)	120dB continuous, 126dB peak
IMPEDANCE	8 ohms nominal
CROSSOVER	120Hz, switchable passive/active
ENCLOSURE	55 litre (1.94 cu foot) vented, multi-laminate birch ply
FINISH	Textured black paint
PROTECTIVE GRILLE	Black perforated steel
CONNECTORS	2 x Neutrik Speakon NL4
FITTINGS	1 x top hat fitting
DIMENSIONS	(W) 398mm x (H) 571mm x (D) 364mm (W) 15.6ins x (H) 22.5ins x (D) 14.3ins
WEIGHT	20kg (44lbs)
SHIPPING DIMENSIONS	(W) 480mm x (H) 510mm x (D) 660mm (W) 19ins x (H) 20ins x (D) 26ins
SHIPPING WEIGHT	28kg (61.5lbs)

Notes

1. Measured on-axis in half space at 2 metres, then referred to 1 metre.
2. AES Standard ANSI S4.26-1984.
3. Measured in half space conditions at 2 metres with 1 watt input, using band limited pink noise, then referred to 1 metre.
4. Measured in half space conditions at 2 metres using band limited pink noise, then referred to 1 metre.

Due to our policy of continuous improvement all specifications are subject to change without notice.

# Blackline F8/F10/S12



Please Click here to  
return to main menu



Please Click here to  
visit our website



**The Martin Experience**

Century Point, Halifax Road, Cressex Business Park, High Wycombe, Buckinghamshire HP12 3SL, England.

Telephone: +44 (0)1494 535312 Facsimile: +44 (0)1494 438669

Web: [www.martin-audio.com](http://www.martin-audio.com) E-mail: [info@martin-audio.com](mailto:info@martin-audio.com)

All material © 2007. Martin Audio Ltd. Subject to change without notice.

# Blackline F8/F10/S12

## User's Guide



**ENGLISH**



**The Martin Experience**